

Flange adaptor RK type

PN10  
PN16

WATER

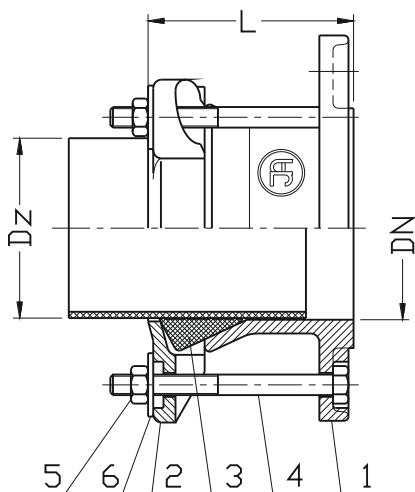

No.	Part	Standard execution
1	Body	Ductile cast iron EN-GJS 500-7
2	Flange	EN 1563
3	Gasket	Rubber EPDM EN ISO1629
4	Screw	Steel Fe/Zn5 Stainless steel A2 EN ISO 4017
5	Nut	Steel Fe/Zn5 Stainless steel A4 EN ISO 4032
6	Washer	Steel Fe/Zn5 Stainless steel A2 EN ISO 7091

DN	D <sub>z</sub>	L	Weight
			[kg]
	[mm]		
50 / 65	57-72	120	5,0
50 / 65 / 80	68-85	120	6,0
80 / 100	84-106	120	6,0
100 / 125	103-116 / 108-130	120	7,0 / 7,8
125 / 150	128-146 / 134-154	120	9,0 / 9,6
150 / 175 / 200	153-175 / 165-185	120	11,0
		120	
175 / 200	184-207	120	13,6
		120	
200	208-225 / 218-236 / 222-250	150	14,5
		150	
250	246-270 / 264-284 / 282-306	150	18,5 / 18,5 / 22,0
		150	
300	305-326 / 315-335 / 334-355 / 360-386	150	23,0 / 27,0 / 28,0 / 36,0
		150	
350	386-410	150	25,0 / 28,0
400	408-435 / 425-458 / 465-500	180	28,0 / 30,0 / 44,0
		180	

### Product description (standard execution):

- Acceptable axial deviation at each end up to ±4°
- EPDM Rubber sealing approved for potable water
- Stainless steel or galvanized nuts and screws
- Plastic protection caps at screw ends
- Installation in any position allowed
- Body and flange made of ductile cast iron EN-GJS 500-7
- Grooved gasket absorbs minor imperfections of the pipe surface
- Epoxy coating minimum 250 microns according to EN ISO 12944- 5
- Product marking according to EN 1092-2 (DIN 2501); pressure PN10; PN16
- Face to face according to the Jafar documentation

### Application:

Water line networks: potable water and other chemically inert fluids. Connection of straight naked-end pipes made of cast iron, asbestos-cement or PVC to fittings flange  
Working pressure up to 1.6 MPa, temperature up to +70°C

### Test control:

Water pressure test according to EN 1074-1; EN 12266-1  
Seat: 1,1xPN  
Body: 1,5 x PN

We reserve the rights to modify the production program and the given data without separate notices due to the permanent company development