

## Flange adaptor for PE and PVC pipes

PN10  
PN16

WATER



No.	Part	Standard execution
1	Body	Ductile cast iron
2	Flange	EN-GJS 500-7 EN 1563
3	Ring	Brass CuZn39PbA11-B EN 1982
4	Ring FORSHEDA 575	Rubber EPDM EN-ISO 1629
5	Screw	Stainless steel A2 EN ISO 4017
6	Washer	Stainless steel A2 EN ISO 7091
7	Pipe	PE, EN ISO 1872-1

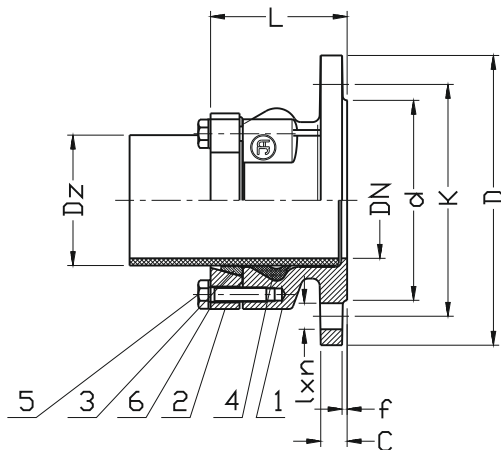

DN	D <sub>z</sub>	D PN16 (PN10)	K PN16 (PN10)	d	l x n PN16 (PN10)	f	C	L	Weight
[mm]									[kg]
50	63	165	125	102	19x4	3	19	90	3,8
80	90	200	160	138	19x8(4)	3	19	95	5,5
100	110	220	180	156	19x8	3	19	95	6,5
100	125	220	180	156	19x8	3	19	102	7,2
125	125	250	210	188	19x8	3	19	100	8,3
150	160	285	240	215	23x8	3	19	115	11,6
200	200	340	295	268	23x12(8)	3	20	139	14,5
200	225	340	295	268	23x12(8)	3	20	141	15,8
250	250	400	355 (350)	320	28(23)x12	3	22	156	22,0
250	280	400	355 (350)	320	28(23)x12	3	22	161	23
300	315	455	410 (400)	378	28(23)x12	4	25	180	33
300	355	455	410 (400)	378	28(23)x12	4	25	285	55
400	400	580	525(515)	480	31(28)x16	4	25	245	53
400	450	580	525(515)	480	31(28)x16	4	25	315	71
500	500	715(670)	650(620)	582	34(28)x20	4	26	340	90
500	560	715(670)	650(620)	582	34(28)x20	4	26	410	105
600	630	840(760)	770(725)	720	37(31)x20	5	30	478	145

### Product description (standard execution):

- Flexible positioning of the pipe with a buffer zone
- The brass clamp ring hold and protect against pipe movements
- Acceptable axial deviation up to ±4°
- EPDM sealing approved for potable water, chemically resistant and providing
- Excellent compression and recovery to the original shape
- Sealing and strengthening kit
- The sealing and flange included as a set
- Construction pressure of 35 bars EN 12842. Operating pressure max 16 bar
- In case of thin-walled PVC pipes, strengthening sleeve should be used inside the pipe
- Epoxy coating minimum 250 microns according to EN ISO 12944- 5
- Product marking according to EN 1092-2 (DIN 2501); pressure PN10; PN16

### Application:

Water line networks: potable water and other chemically inert fluids. Flanged connectors for naked-end pipes made of PVC or PE  
Working pressure up to 1.6 MPa, temperature up to +70°C

### Test control:

Water pressure test according to EN 1074-1; EN 12266-1  
Sea: 1,1 x PN  
Body: 1,5 x PN

We reserve the rights to modify the production program and the given data without separate notices due to the permanent company development